

NOTE:
 PUMPER CONNECTIONS
 FACE BUILDINGS OR STREET.

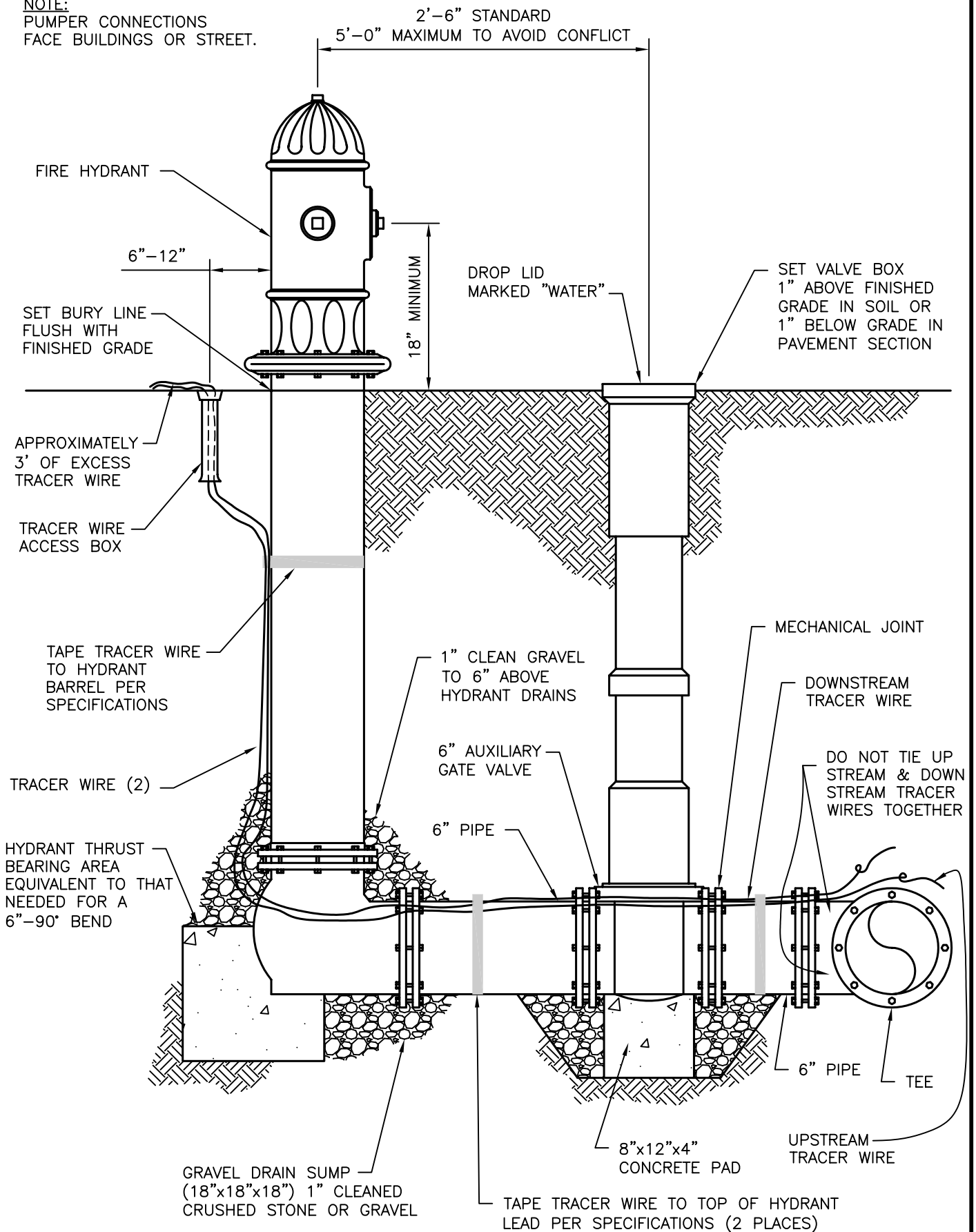

CITY OF RAPID CITY

PUBLIC WORKS DEPARTMENT

HYDRANT SETTING DETAIL

DATE: 5-1-07

SEC. SHT.

8-1

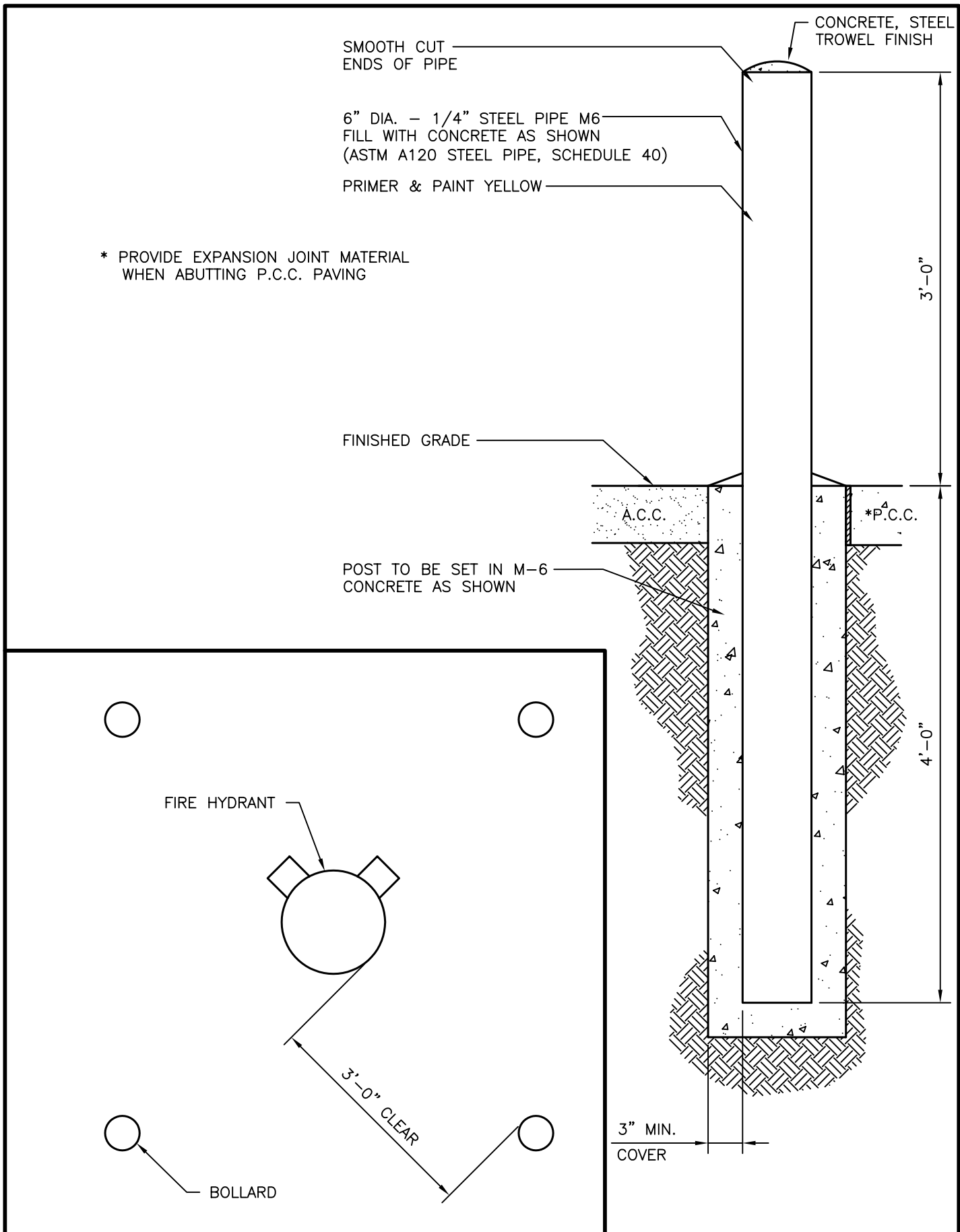

CITY OF RAPID CITY

PUBLIC WORKS DEPARTMENT

FIRE HYDRANT PROTECTION
BOLLARD DETAIL

DATE: 5-1-07

SEC. SHT.

8-2

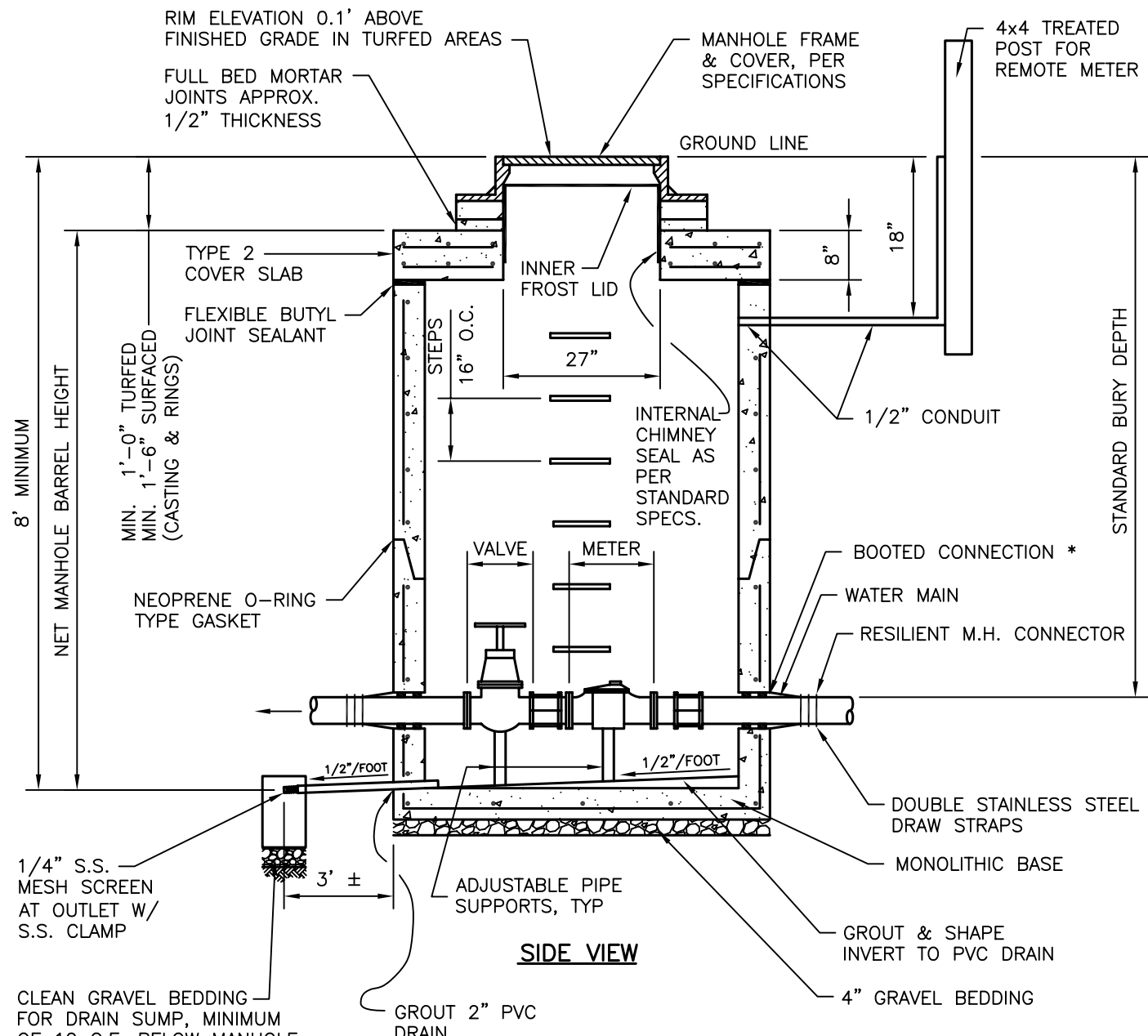

SIDE VIEW

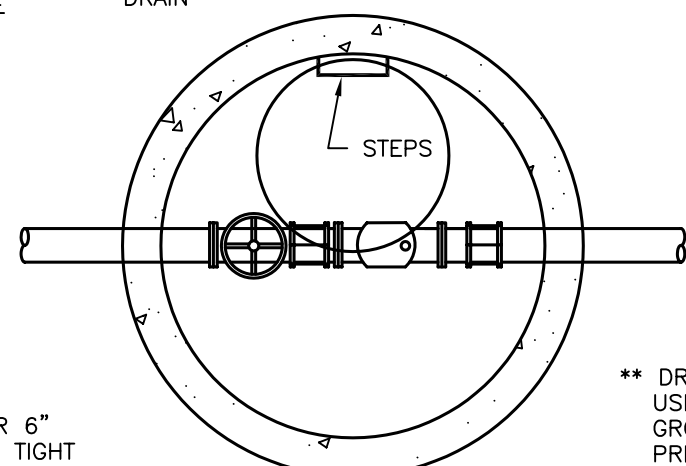

PLAN VIEW

CLEAN GRAVEL BEDDING FOR DRAIN SUMP, MINIMUM OF 10 C.F. BELOW MANHOLE FLOOR **

* BOOTED CONNECTIONS FOR 6" AND LARGER PIPE. WATER TIGHT CONNECTION, PER DETAIL 9-6, FOR 6" AND SMALLER PIPE.

** DRAIN SUMP TO ONLY BE USED IN INSTALLATIONS WHERE GROUND WATER WILL NOT BE PRESENT. IF GROUND WATER WILL BE PRESENT, THEN OTHER ALTERNATIVES WILL NEED TO BE USED.

CITY OF RAPID CITY		PUBLIC WORKS DEPARTMENT	
<h1>TYPICAL METER PIT DETAIL</h1> <h2>4" METER & UNDER</h2>		DATE: 5-1-07	
		SEC. 8	SHT. 3

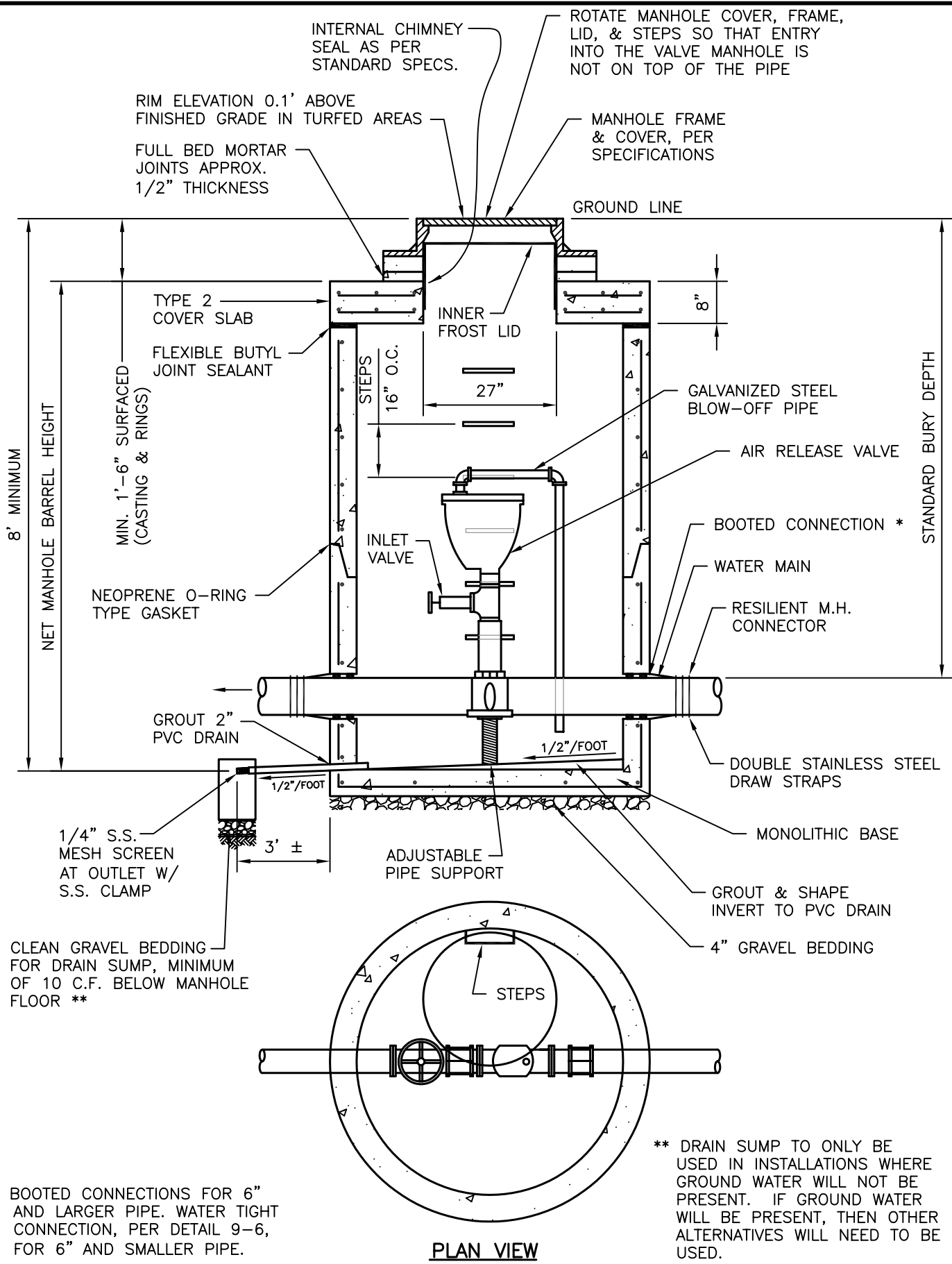

CITY OF RAPID CITY

PUBLIC WORKS DEPARTMENT

DATE: 5-1-07

AIR RELEASE VALVE PIT

SEC. SHT.

8-4

**MULTI-UNIT, SINGLE OWNER,
MULTIPLE METERS**

**MULTI-UNIT, SINGLE OWNER,
SINGLE METER**

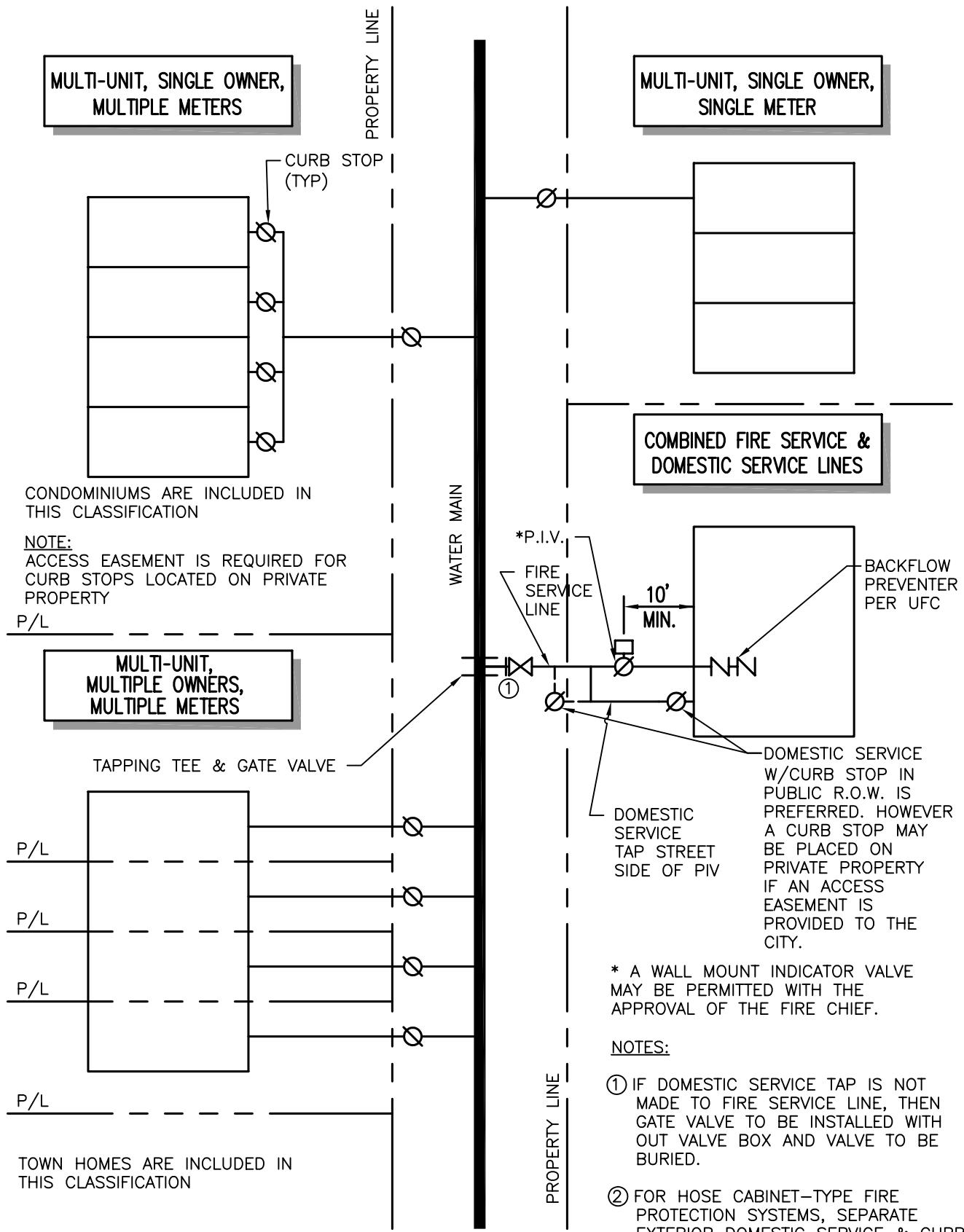

CONDOMINIUMS ARE INCLUDED IN THIS CLASSIFICATION

NOTE:
ACCESS EASEMENT IS REQUIRED FOR CURB STOPS LOCATED ON PRIVATE PROPERTY

P/L

**MULTI-UNIT,
MULTIPLE OWNERS,
MULTIPLE METERS**

TAPPING TEE & GATE VALVE

P/L

P/L

P/L

P/L

TOWN HOMES ARE INCLUDED IN THIS CLASSIFICATION

**COMBINED FIRE SERVICE &
DOMESTIC SERVICE LINES**

*P.I.V.

FIRE SERVICE LINE

10' MIN.

BACKFLOW PREVENTER PER UFC

DOMESTIC SERVICE W/CURB STOP IN PUBLIC R.O.W. IS PREFERRED. HOWEVER A CURB STOP MAY BE PLACED ON PRIVATE PROPERTY IF AN ACCESS EASEMENT IS PROVIDED TO THE CITY.

DOMESTIC SERVICE TAP STREET SIDE OF PIV

* A WALL MOUNT INDICATOR VALVE MAY BE PERMITTED WITH THE APPROVAL OF THE FIRE CHIEF.

- NOTES:**
- ① IF DOMESTIC SERVICE TAP IS NOT MADE TO FIRE SERVICE LINE, THEN GATE VALVE TO BE INSTALLED WITH OUT VALVE BOX AND VALVE TO BE BURIED.
 - ② FOR HOSE CABINET-TYPE FIRE PROTECTION SYSTEMS, SEPARATE EXTERIOR DOMESTIC SERVICE & CURB STOP AS SHOWN ABOVE ARE NOT REQUIRED.